

ORIGINAL
 Red Ink Indicates
 Original Copy

REV **D**
S-1014
 DRAWING NO.

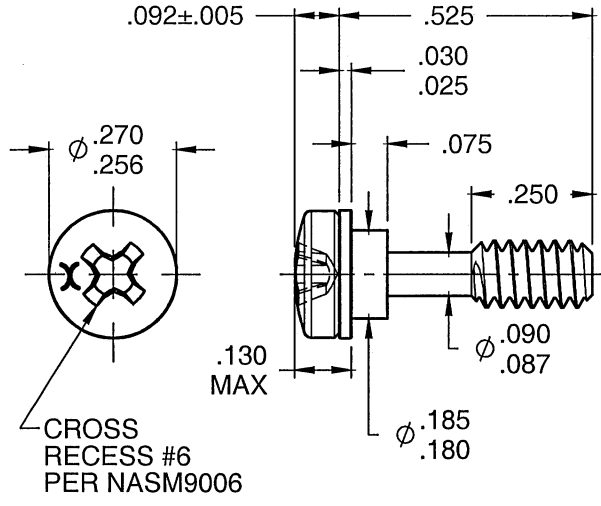

ASSEMBLY BEFORE MOUNTING

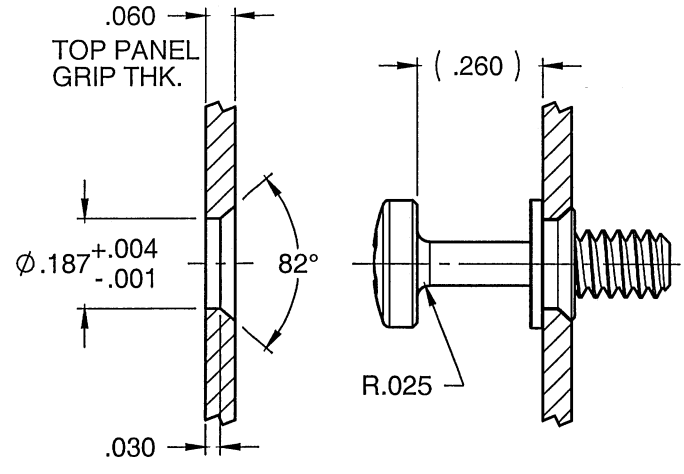

PANEL PREPARATION

ASSEMBLY AFTER MOUNTING

PART NUMBER CALLOUT

SCD 7900 -6F -A -4

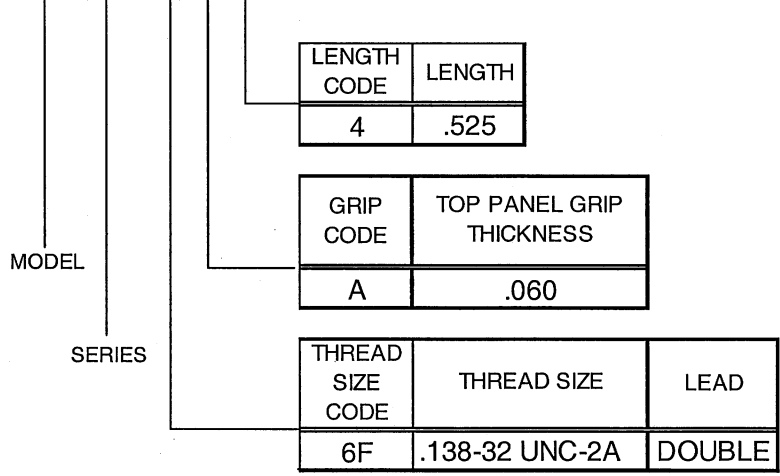

INSTALLATION TOOLS:

ARBOR PRESS TOOL: SCD7600-6F

COMPLETE HAND TOOL ASSEMBLY:
 SCD8603-6F (INCLUDES NOSE PIECE,
 PULLER & HANDLE)

MATERIAL:

SCREW:
 4037 ALLOY STEEL PER AMS 6300 OR 8740 ALLOY STEEL PER AMS 6322,
 HEAT TREAT TO HRC 34-38.

SLEEVE:
 BRASS ALLOY PER AMS 4610 OR ASTM B 16, ANNEALED AFTER MACHINING.

FINISH:

SCREW AND SLEEVE ASSEMBLY:
 CAD PLATE PER AMS QQ-P-416, TYPE II, CLASS 2.

THIS DRAWING, THE STRUCTURAL DESIGN DISCLOSED THEREIN, THE TECHNICAL DATA AND ENGINEERING SERVICE REPRESENTED THEREBY ARE THE EXCLUSIVE PROPERTY OF HUCK INTERNATIONAL, INC.

D	DCN 5141	03-08-07
REV	DESCRIPTION/EC NO.	DATE

UNLESS OTHERWISE SPECIFIED
 ALL DIMENSIONS IN INCHES
 TOLERANCE UNLESS OTHERWISE
 NOTED:
 .X = ±.05 ANGLES ±0.5°
 .XX = ±.02
 .XXX = ±.015

Alcoa Fastening Systems
 AEROSPACE FASTENER DIVISION
 3724 EAST COLUMBIA STREET
 TUCSON, ARIZONA 85714
 PHONE 520 519-7400
 FAX 520 519-7427
 www.alcoafasteners.com

TITLE CAPTIVE SCREW, PAN HEAD, CROSS RECESS, 6-32 UNC-2A, DOUBLE LEAD			
DATE	03/08/2007	PART NUMBER	SCD7900
DRAWN	JLS	DRAWING NO.	S-1014
CHECK		CAGE CODE	0HDW7
APPROVE		REV	D
SCALE: 2.5:1		SHEET 1 OF 1	